

INSTALLATION GUIDE

G-DOCK RACK



SCAN THIS QR CODE FOR
THE FULL INSTALL VIDEO.
or visit bit.ly/dockrack (CASE SENSITIVE)

IMPORTANT INFORMATION

G-Dock Rack

Manufactured for Spire LLC by Tellbe in Vietnam

Quantity: 1

WARNING! The G-Dock Rack is NOT intended for use by any person under the age of 18 years old. You must be over the age of 18 to install or use the G-Dock Rack.

WARNING! Strictly follow all instructions to avoid an accident, damage to property, personal injury or death.

WARNING! Do not use this product for human suspension. Components can fail causing person to fall, possibly resulting in serious injury or death.

WARNING! When operating system, make sure the area below object is clear of persons. If object comes down too quickly, this can cause an accident.

READ THE ENTIRE USER MANUAL BEFORE INSTALLATION

The User Manual you received with your G-Dock Rack provides instructions on how to install and use your G-Dock Rack. The instructions are written for a person with a basic understanding of tools and procedures. Read the entire manual before proceeding. If you do not understand any portion of the instructions, do not attempt installation, and call 1-877-880-5934.

CORRECTLY INSTALL THE PRODUCT

Read and follow all instructions carefully.

Failure to properly install and use the G-Dock Rack could allow the product to detach from the dock, injuring persons or personal property in the process. Accordingly, it is critical that the G-Dock Rack be installed correctly and according to the instructions in the User Manual.

USE TOOLS SAFELY

The procedures in the User Manual may require climbing ladders and/or operating power tools. Make sure you are familiar with these tools and their safety procedures before attempting to use such tools during installation. Always be aware of electrical wires during installation. Failure to do so could result in an electrical shock or death.

WARNING!

Contact with wires can give you a severe electrical shock, which may cause injury or death. If you do not know where wires are, have the work done by an experienced professional.

IMPORTANT INFORMATION

CAUTION

It is the consumer's responsibility to install this system in accordance with all codes, ordinances, and local regulations.

When installing the G-Dock Rack, it is the consumer's responsibility to ensure the structural integrity of the structure it is being mounted to.

The G-Dock Rack is intended for the storage of sporting equipment only. Do not use it for any other purpose.

This system has a maximum capacity of 400 lbs. Overloading the system could result in damage to property or injury.

Use extreme caution when loading and unloading equipment from this system.

It is the consumer's responsibility to ensure that the system is in proper working condition before loading objects onto the system. Check tightness of all bolts and screws periodically. Failure to properly maintain the system could result in damage to property or injury.

WARNING AND DISCLAIMER

Spire LLC (d/b/a StoreYourBoard) expressly disclaims any and all liability for personal injury, property damage or loss, whether direct, indirect, incidental, resulting from the incorrect mounting, improper use, inadequate maintenance, or neglect of this system.

INSTALLATION

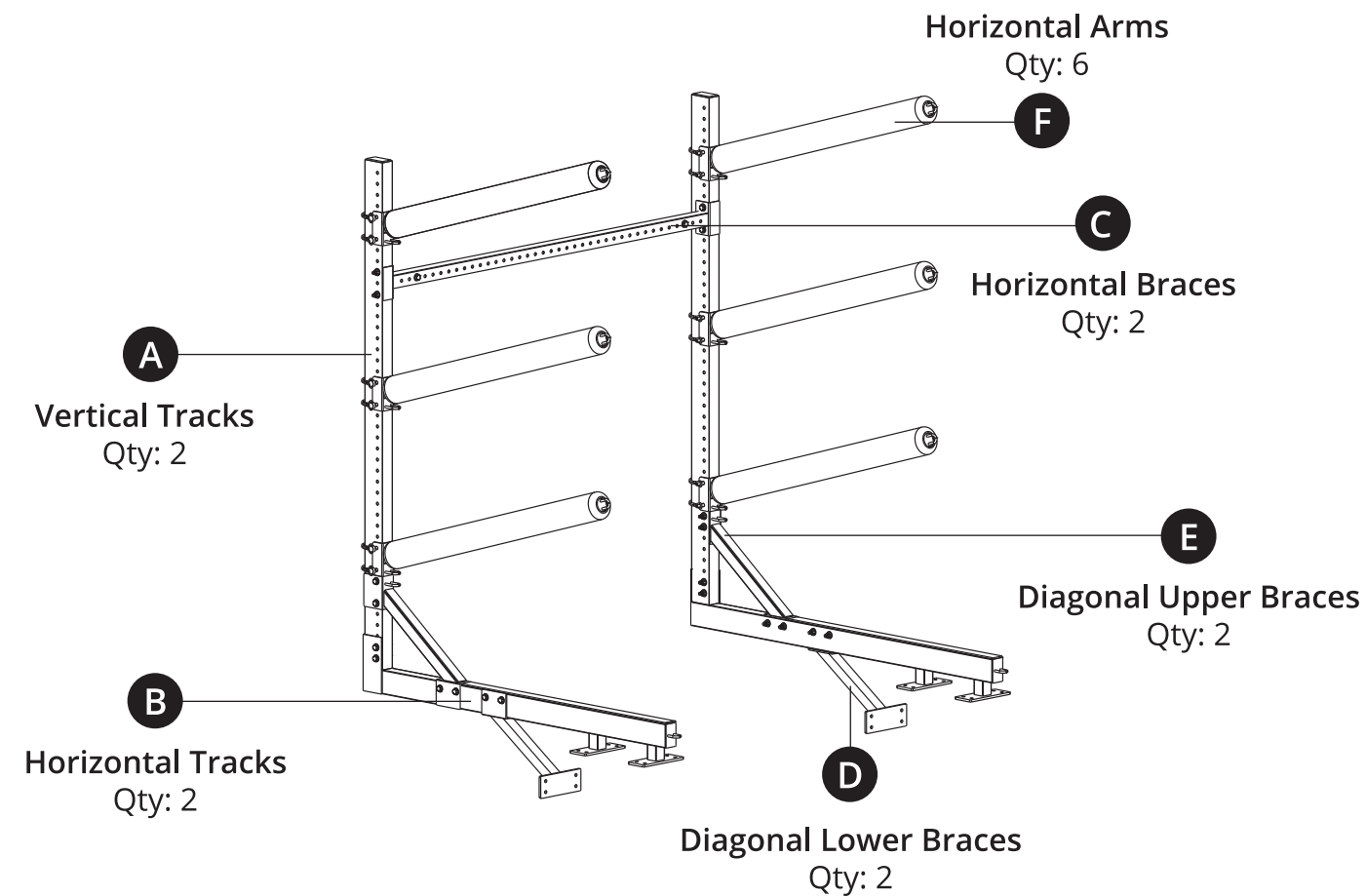

INCLUDED HARDWARE:

				
G	H	I	J	K
Quick Release Pins Qty: 12	Hex Bolts Qty: 22	Hex Nuts Qty: 22	Dock Mounting Screws Qty: 24	Washers Qty: 68

RECOMMENDED TOOLS:

- Drill/driver
- Drill bits
- Socket wrench w/ extension
- Level
- Tape measure
- Pencil

WEIGHT LIMITS:

- 50 lbs. max per storage arm
- 100 lbs. max per level
- 400 lbs. max total

*weight must be evenly distributed

NOTE: We recommend assembling this rack with 2 or more people

1

Fasten the Vertical Tracks (A) to the left and right Horizontal Tracks (B). Use 2 Hex Bolts (H), 4 Washers (K), and 2 Hex Nuts (I) per side. Take note of the orientation in the picture

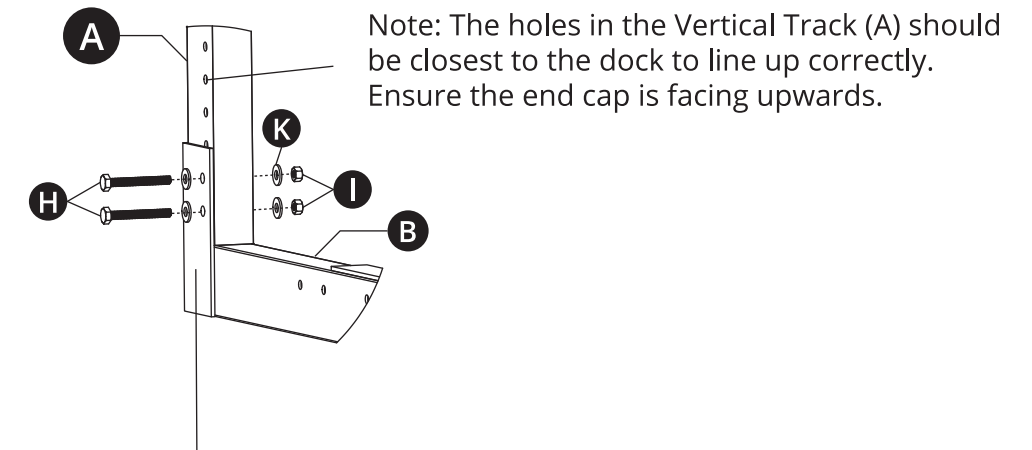

Note: The flange on the Horizontal Tracks (B) should be on the outside. Left and right are not interchangeable. (Left shown)

2

Fasten the left and right Diagonal Upper Brace (E) to the previously assembled Vertical Tracks (A) and Horizontal Tracks (B). Use 4 Hex Bolts (H), 8 Washers (K), and 4 Hex Nuts (I) per side

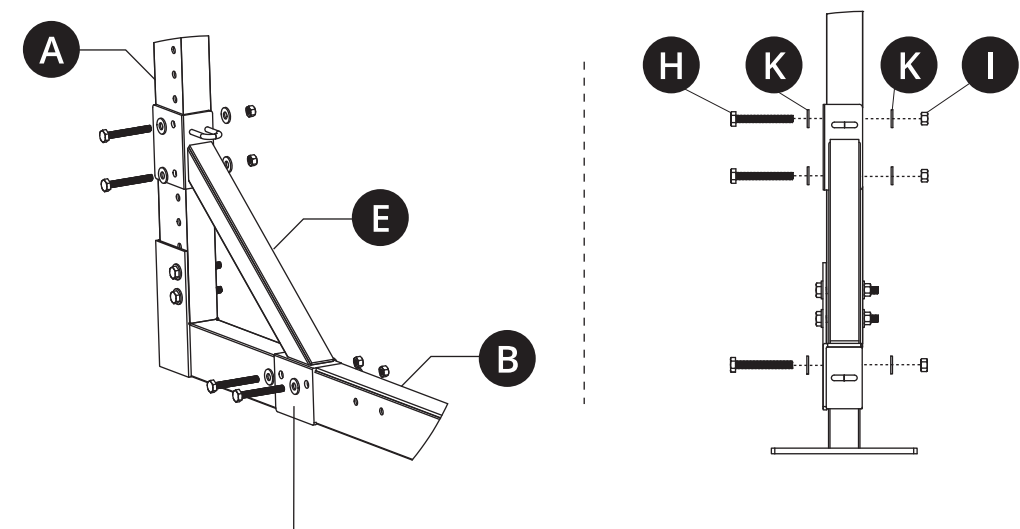

Note: The flange on the Diagonal Upper Braces (E) should be on the outside. (Left shown)

NOTE: We recommend assembling this rack with 2 or more people

3

Determine the length of items to be stored and the spacing necessary to ensure proper stability. Please refer to the user manual of each item. If it is not specified, use 40% of the item's length to determine the appropriate spacing needed (i.e. 10' x 0.4 = 4').

Adjust the L/R Horizontal Braces (C) to match the required spacing. Fasten the two braces together using 2 Machine Bolts (H), 4 Machine Washers (K), and 2 Machine Nuts (I).

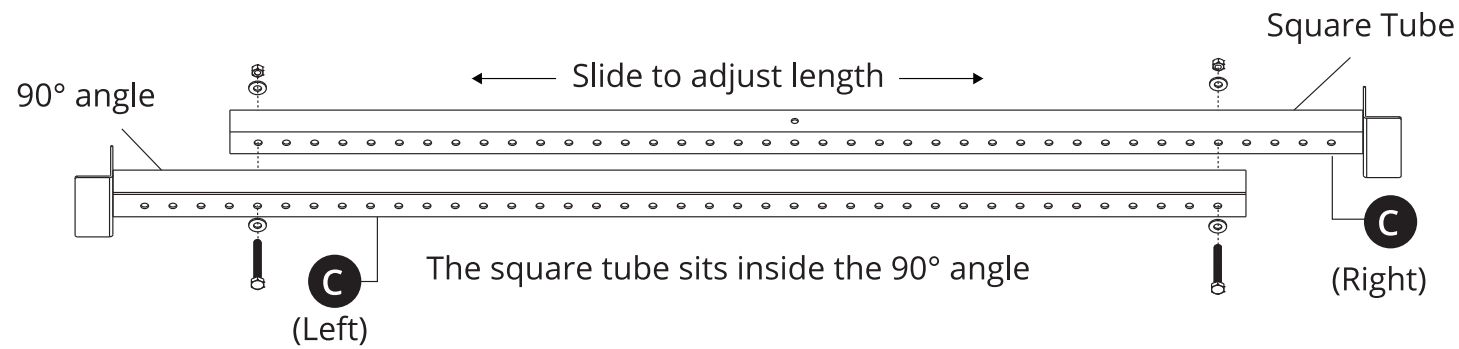

Note: The Machine Bolts should be positioned as far apart as possible while still fastening the L/R Horizontal Braces (C) together, reference picture above.

4

Fasten the previously assembled Horizontal Brace (C) to the Vertical Tracks (A). Use 2 Hex Bolts (H), 4 Washers (K), and 2 Hex Nuts (I) per side.

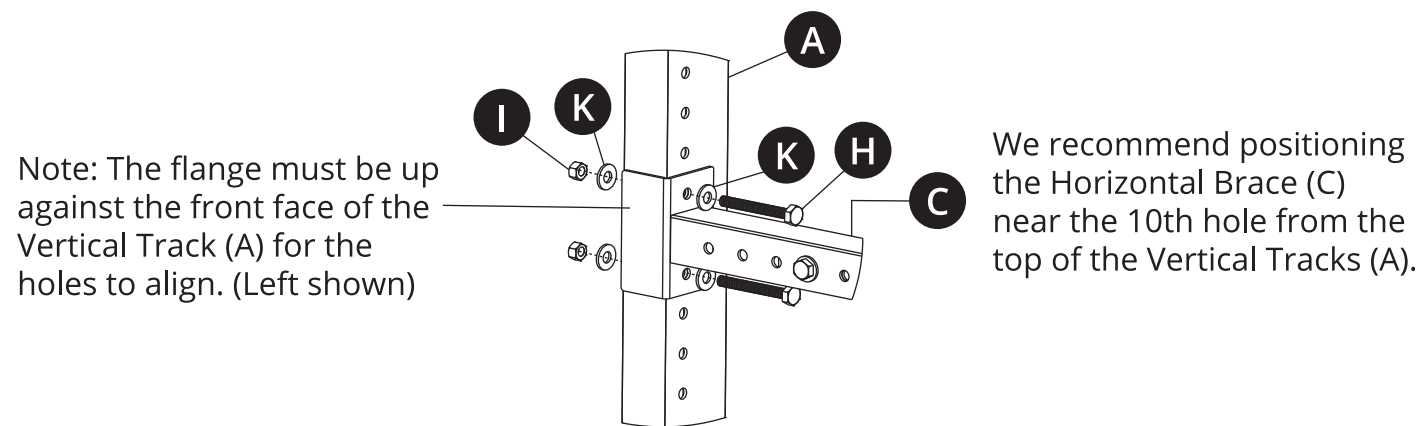

5

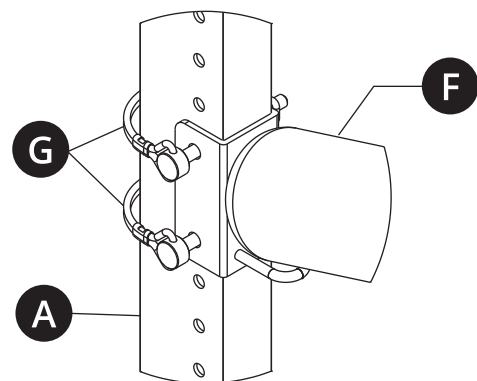

Attach Horizontal Arms (F) to the Vertical Tracks (A). Use 2 Quick Release Pins (G) per Horizontal Arms (F).

Note: Horizontal Arms (F) should be placed at the same height on each side so the item will be level

NOTE: We recommend assembling this rack with 2 or more people

6

Roll the rack onto the back of the Vertical Tracks (A) and fasten Diagonal Lower Braces (D) to the left and right Horizontal Base Tracks (B). Use 2 Hex Bolts (H), 4 Washers (K), and 2 Hex Nuts (I) per side.

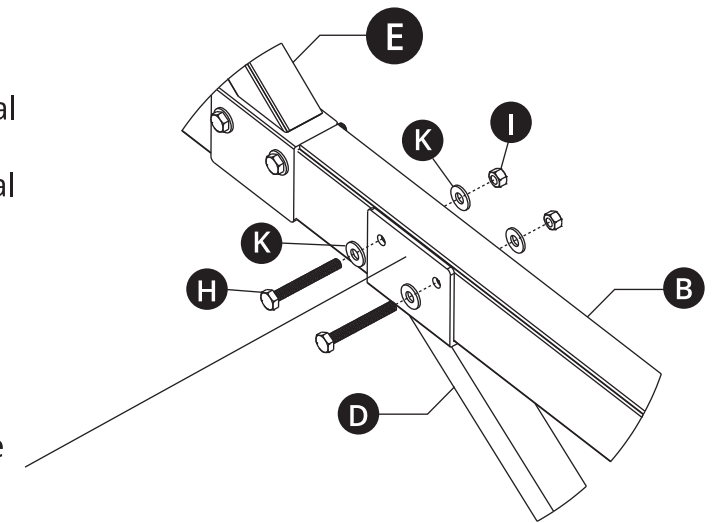

Note: The flange must be on the outside of the Horizontal Track (A). (Left shown)

7

Now that the rack is fully assembled, use two people to carry it to the desired location and set the rack in place. Adjust so that no mounting holes are aligned with gaps between boards on the dock. With one person holding the rack still, another should mark all 24 mounting holes with a pencil.

8

With the holes marked, move the rack out of the way. Use a 3/32" (2.5mm) drill bit to create pilot holes on the marked locations.

9

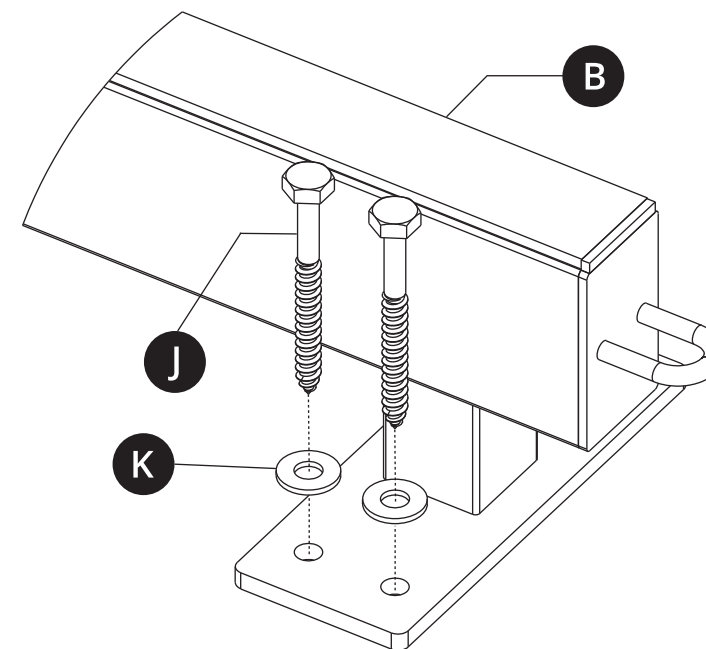

Set the rack back in place and align the mounting holes with the pilot holes.

With one person holding the rack still, another should mount the rack to the dock using the Dock Mounting Screws (J) and Washers (K).