



THE **Naked Rack for BIKE**

PART OF THE
Naked Rack
LINE OF PRODUCTS

by

StoreYourBoard™

Patent Pending

THANK YOU FOR YOUR PURCHASE!

Please read all instructions before installing this product

WARNINGS:

It is the user's responsibility to ensure the safe and proper use of this product. StoreYourBoard is not responsible for damages or injuries related to installation or use, including improper or inadequate mounting. Wear eye protection and locate electrical wiring in walls before installation. Not intended for children. **Misuse of this product could result in serious injury or death.**

Rack Contents:

- (1) Wall Rack (Mounting Rod & Attachment Arm)
- (2) Lag Screws & (2) Washers
- (1) Hook & Loop Strap
- (1) Set Screw per rack w/ (1) hex key per kit

Weight Limits:

- **Up to 50 lbs per rack** (evenly distributed)

Installation Instructions

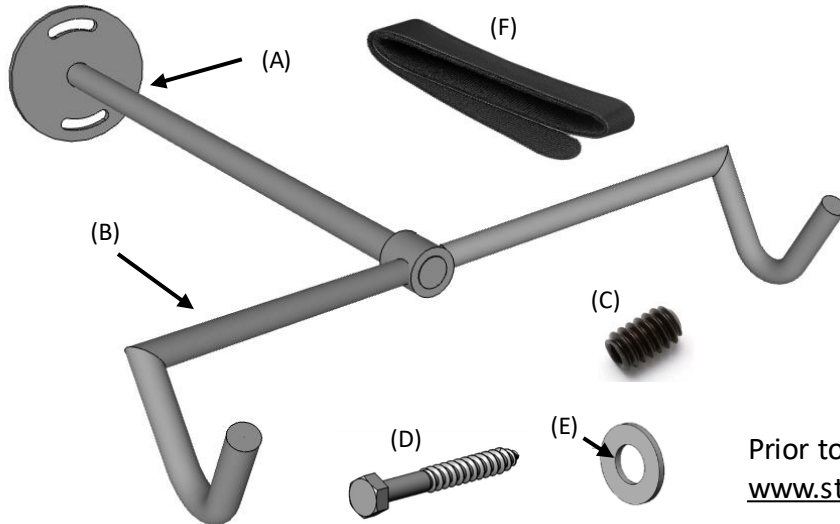

Part Identification:

- (A) Mounting Rod
- (B) Attachment Arms
- (C) Set Screw
- (D) Lag Screw
- (E) Washers
- (F) Hook & Loop Strap

Recommended Tools:

- Drill/Driver
- Nut drivers
- Drill bits
- Stud Finder & Pencil
- Tape Measure

Prior to installing, please visit the product details page at www.storeyourboard.com to view installation videos.

- Locate Studs:** Determine the wall space where the Naked Rack for Bike Rack is to be located. Use a Stud Finder to locate your nearest wall stud to the desired rack location, mark the stud location with a pencil.
Do Not anchor through drywall only.
- Mark Mounting Points:** Hold the rack Mounting Rod (A) up to the wall at the desired mounting height (consider the length of the bike to stored as well as the desired height off the floor). Align rack mounting holes with the marked stud location and mark the mounting hole locations with a pencil.
Note: The holes shall be vertical and centered on the marked stud. The rack mounting slots provide desired angle adjustment after installing.
- Pre-drill Mounting Holes:** Locate a drill bit that is slightly narrower than the threads of the lag screw (D) provided. With the selected drill bit, drill holes into the wall studs at the mounting points marked in step 2. The depth of the hole should be similar to that of the lag screw provided.
- Secure Mounting Rod to Wall:** Locate a nut driver (or socket) sized for the lag screws provided. Place a washer (E) over the lag screw (D) and install thru the top slot in the Mounting Rod (A). The Mounting Rod has a hole at the end of the rod which shall face the ground once secured to the wall. Tighten the lag screw to secure Mounting Rod to the wall. Repeat for the second lag screw and bottom slot in the Mounting Rod.

- Instructions continued on reverse -



Bringing you the best racks, bags & accessories.

Need help?

info@storeyourboard.com

1.877.880.5934

Updated: 8-27-2019



THE **Naked Rack for BIKE**

PART OF THE
Naked Rack
LINE OF PRODUCTS

by

Store Your Board™

Patent Pending

THANK YOU FOR YOUR PURCHASE!

Please read all instructions before installing this product

Installation Instructions Continued

Image 1 – Set Screw Location

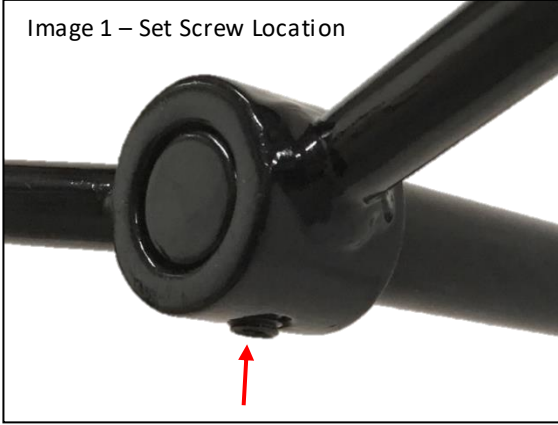

- 5. Assemble Attachment Arms:** Slide the Attachment Arms (B) over the installed **Mounting** Rod (A) aligning the holes on the bottom of the rod as shown in image 1. The U-Shape hooks shall face upwards and away from the wall. Utilizing the provided hex tool, secure the attachment arms to the mounting rod by installing set screw (C) so that it achieves a very snug and rigid connection.
- 6. Test Fit Bike:** Place the bike to be stored on the rack on the u-shaped hooks as shown in image 3 below. *Note: Bike frame configurations vary widely and may differ from that shown below.*

- 7. Adjust Support Angle:** Remove the bike from the rack. Loosen both lag screws installed to the wall slightly a few turns and adjust the angle of the rack to the desired position as to support the bike level with the ground. After adjusting angle, fully secure lag screws to the wall. Repeat as necessary to achieve the desired support angle.



Image 2 – Hook and Loop Strap



Image 3 – Installed Bike Rack

- 8. Load Bike:** Load bike on the installed rack.
- 9. (Optional) Install Strap:** A hook and loop strap is provided for your use to keep the front wheel from rotating and pivoting into the wall while the bike is stored on the rack. If desired, wrap the hook and loop strap (shown in image 2) thru the spokes on the front wheel and then around the bike frame so that the front wheel is strapped to the frame to keep wheel from rotating and pivoting.

Enjoy your new Bike Rack!

We value your feedback:

Help others by leaving a review of your experience with this rack. We at SYB greatly value feedback, and continually look for ways to improve our products to meet your storage needs!

Store Your Board™

Bringing you the best racks, bags & accessories.

Need help?

info@storeyourboard.com

1.877.880.5934

Updated: 8-27-2019