

▲ TEAL TRIANGLE

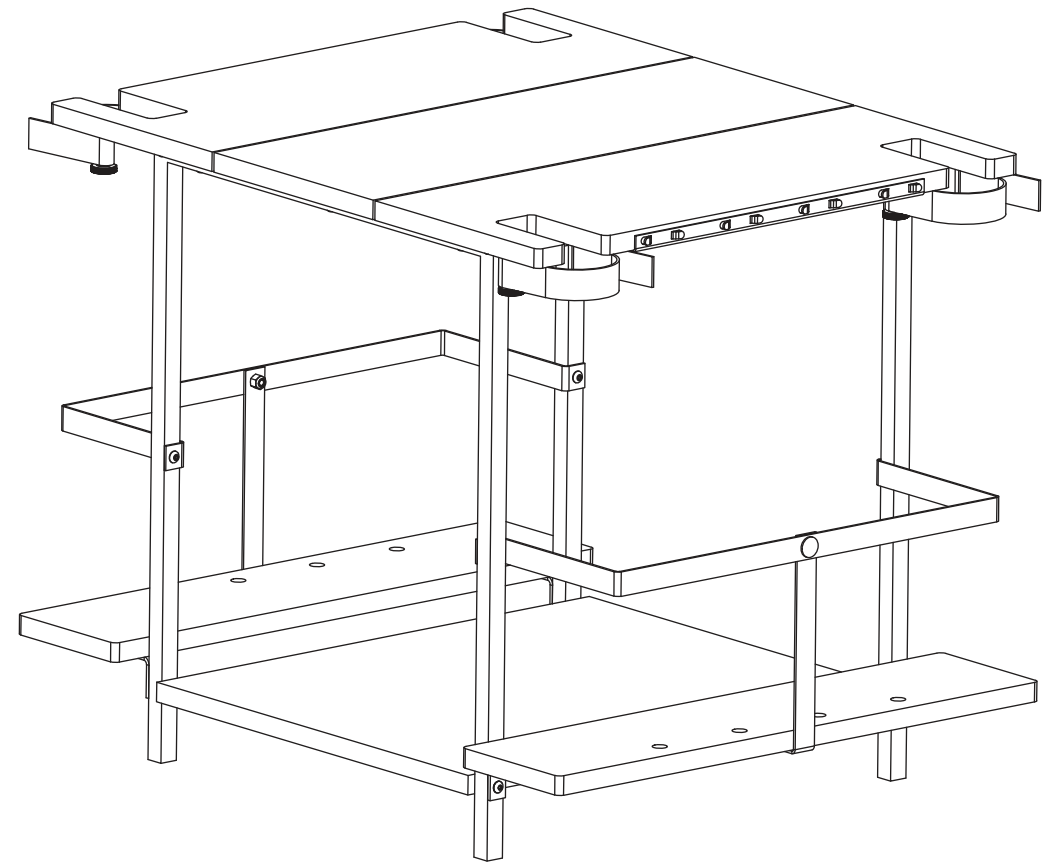

INSTALLATION GUIDE FREESTANDING SKI RACK

Questions or Concerns?

Contact us at: ✉ support@tealtriangle.com

IMPORTANT INFORMATION

Freestanding Ski Rack

Manufactured for Spire LLC in Vietnam

Quantity: 1

WARNING! The Freestanding Ski Rack is NOT intended for use by any person under the age of 18 years old. You must be over the age of 18 to install or use the Freestanding Ski Rack.

WARNING! Strictly follow all instructions to avoid an accident, damage to property, personal injury or death.

WARNING! Do not use this product for human suspension. Components can fail causing person to fall, possibly resulting in serious injury or death.

WARNING! When operating system, make sure the area below object is clear of persons. If object comes down too quickly, this can cause an accident.

READ THE ENTIRE USER MANUAL BEFORE INSTALLATION

The User Manual you received with your Freestanding Ski Rack provides instructions on how to install and use your Freestanding Ski Rack. The instructions are written for a person with a basic understanding of tools and procedures. Read the entire manual before proceeding. If you do not understand any portion of the instructions, do not attempt installation, and email support@tealtriangle.com.

CORRECTLY INSTALL THE PRODUCT

Read and follow all instructions carefully.

Failure to properly install and use the Freestanding Ski Rack could allow the product to disassemble or tip over, injuring persons or personal property in the process. Accordingly, it is critical that the Freestanding Ski Rack be installed correctly and according to the instructions in the User Manual.

USE TOOLS SAFELY

The procedures in the User Manual may require climbing ladders and/or operating power tools. Make sure you are familiar with these tools and their safety procedures before attempting to use such tools during installation. Always be aware of electrical wires during installation. Failure to do so could result in an electrical shock or death.

WARNING!

Contact with wires can give you a severe electrical shock, which may cause injury or death. If you do not know where wires are, have the work done by an experienced professional.

IMPORTANT INFORMATION

CAUTION

It is the consumer's responsibility to install this system in accordance with all codes, ordinances, and local regulations.

When installing the Freestanding Ski Rack, it is the consumer's responsibility to ensure the structural integrity of the structure it is being mounted to.

The Freestanding Ski Rack is intended for the storage of Ski equipment only. Do not use it for any other purpose.

This system has a maximum capacity of 160 lbs. Overloading the system could result in damage to property or injury.

Use extreme caution when loading and unloading equipment from this system.

It is the consumer's responsibility to ensure that the system is in proper working condition before loading objects onto the system. Check tightness of all bolts and screws periodically. Failure to properly maintain the system could result in damage to property or injury.

WARNING AND DISCLAIMER

Spire LLC (d/b/a StoreYourBoard) expressly disclaims any and all liability for personal injury, property damage or loss, whether direct, indirect, incidental, resulting from the incorrect mounting, improper use, inadequate maintenance, or neglect of this system.

INSTALLATION

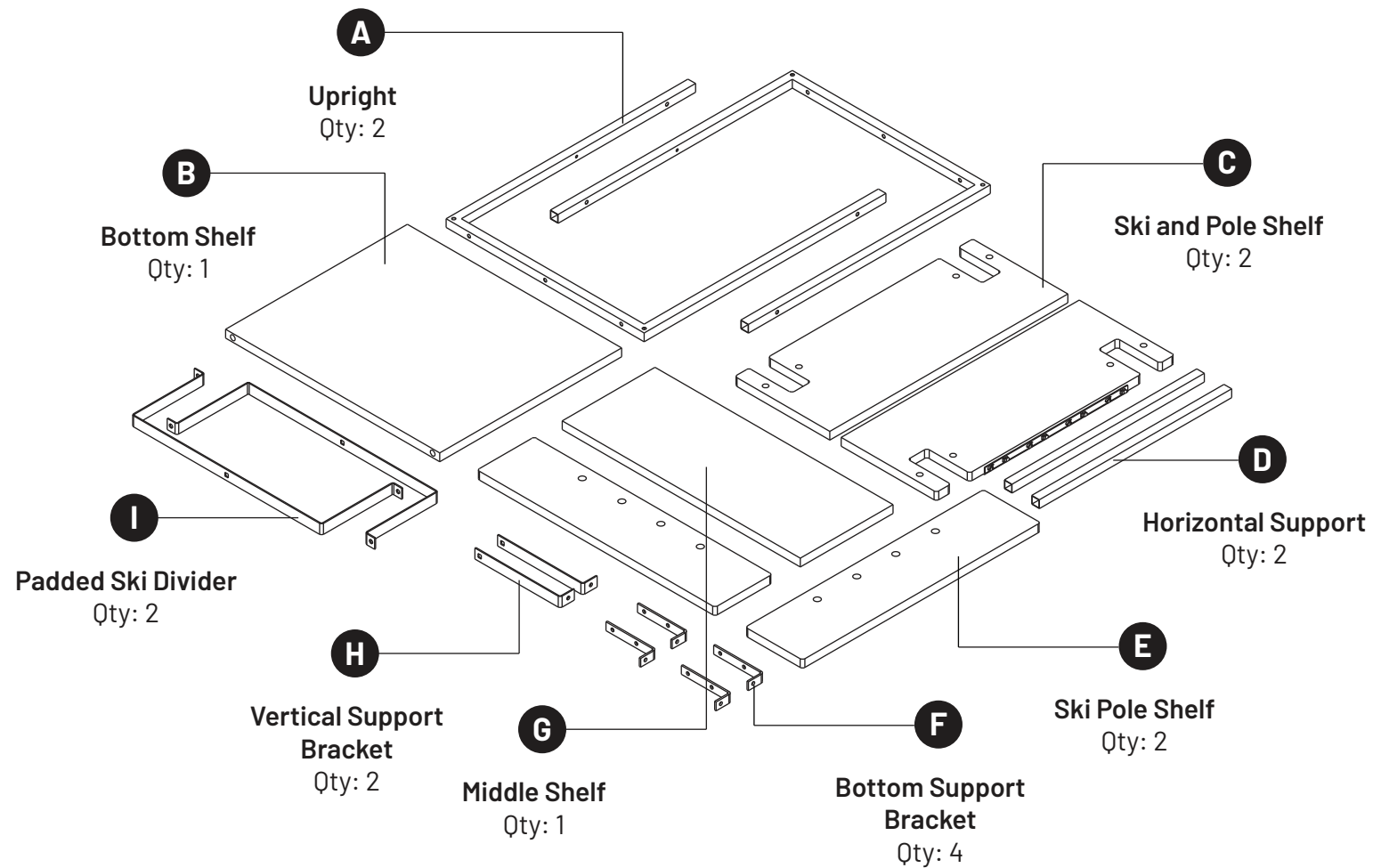

INCLUDED HARDWARE/TOOLS:

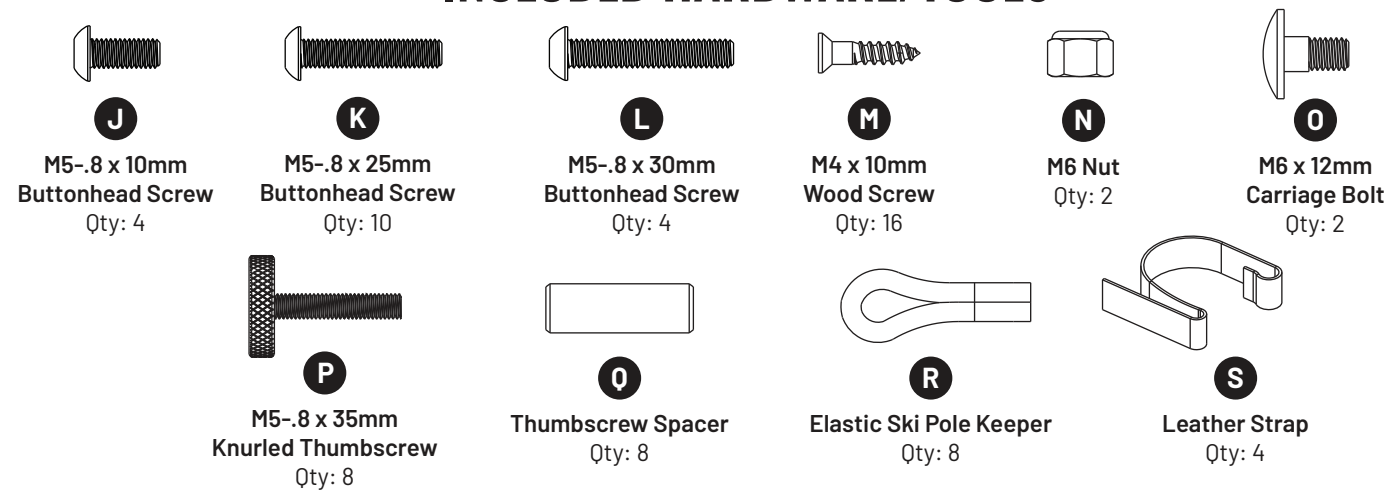

RECOMMENDED TOOLS:

3mm Allen Key (Included)
10mm wrench
Phillips Screwdriver

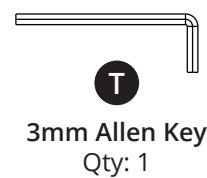

WEIGHT LIMITS:

50 lbs. Per Shelf Level (100lbs total)
30lbs. Per Ski Shelf (60 lbs total)

1 Make the base by fastening the Uprights (A) and Horizontal Supports (D) using four M5x25 (K) buttonhead screws. The correct screws are the medium length buttonscrews.

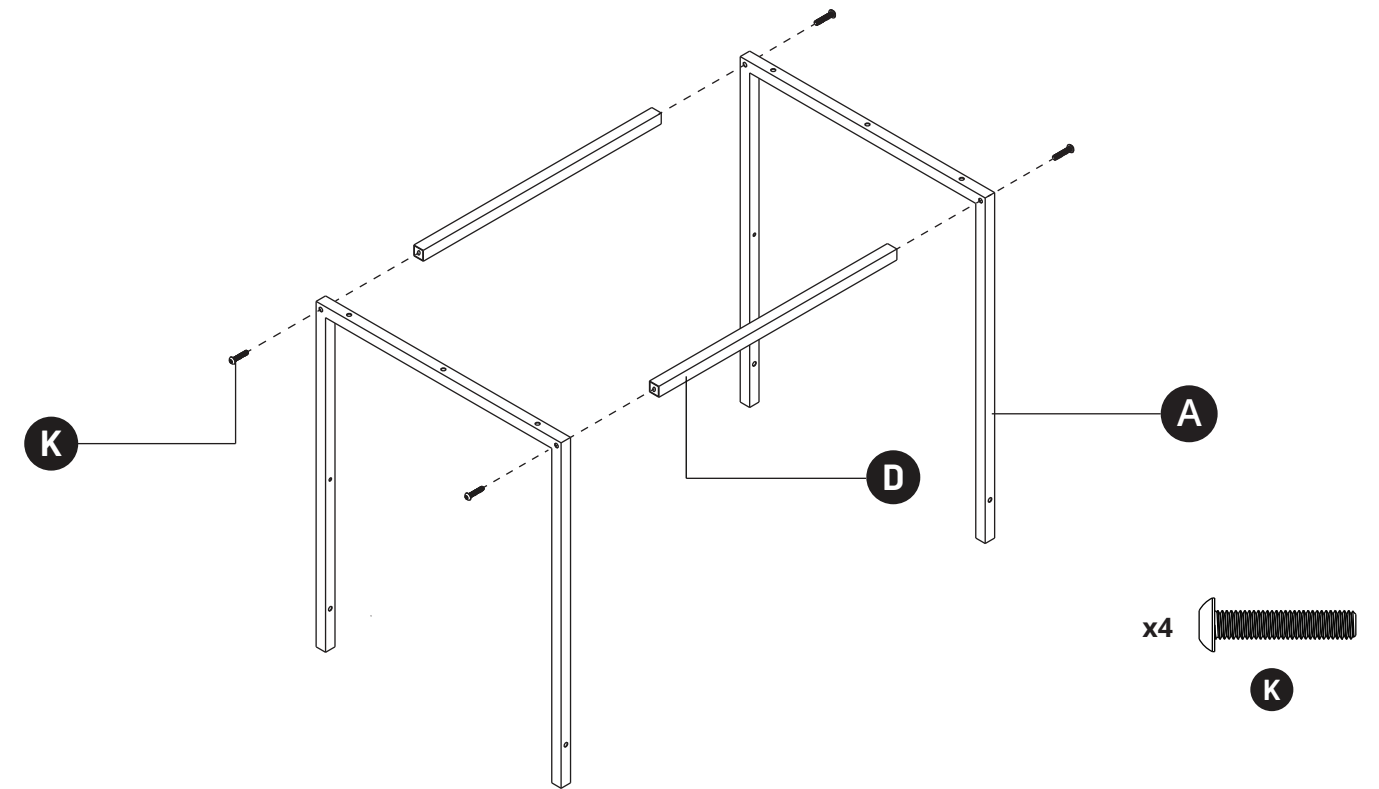

2 Attach the Bottom Shelf (B) to the base along with the Bottom Support Bracket (F) which will share the same hole. Fasten the two components together using an M5 x 30mm (longest) screw (L).

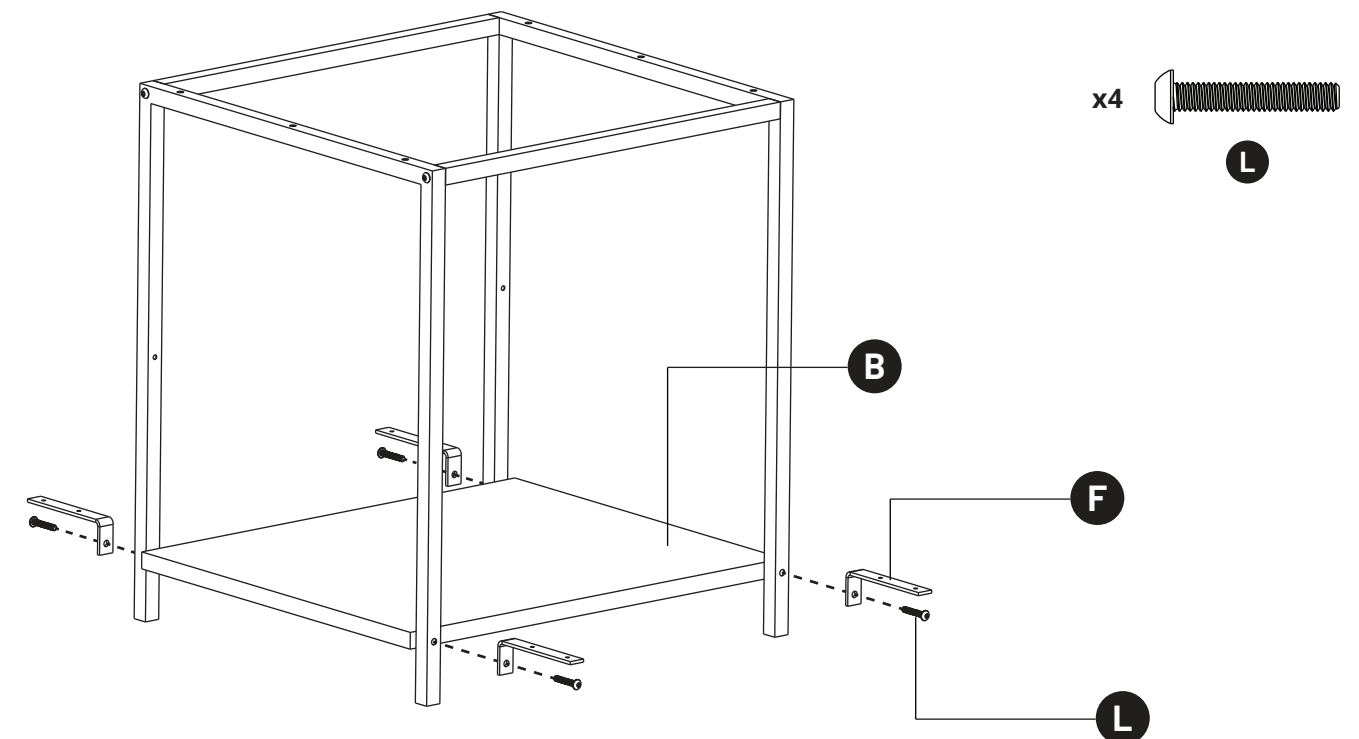

3

Fasten the Ski Pole Shelf (E) to the Bottom Support Bracket (F) using eight M4 x 10mm wood screws (M) using a phillips screwdriver. Ensure the four holes in the Ski Pole Shelf (E) are closest to the outside as seen below.

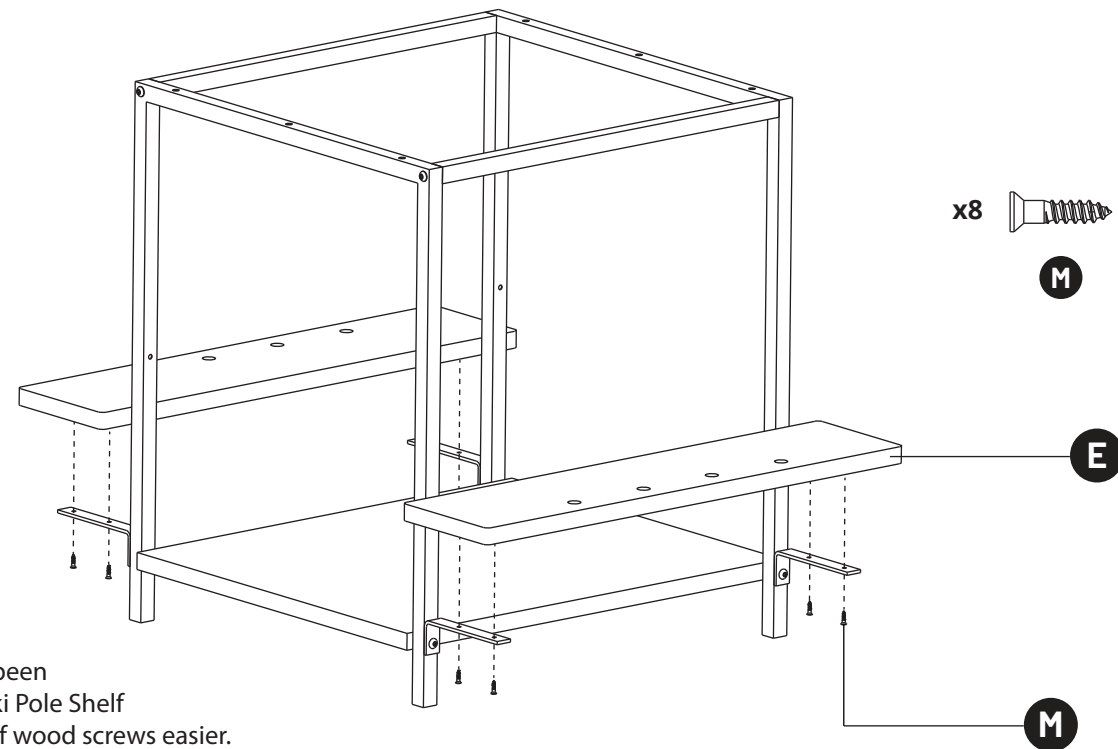

Note: Holes have been pre-drilled in the Ski Pole Shelf to make insertion of wood screws easier.

4

Using two M4 wood screws (M), fasten the Vertical Support Bracket (H) to the Ski Pole Shelf (E).

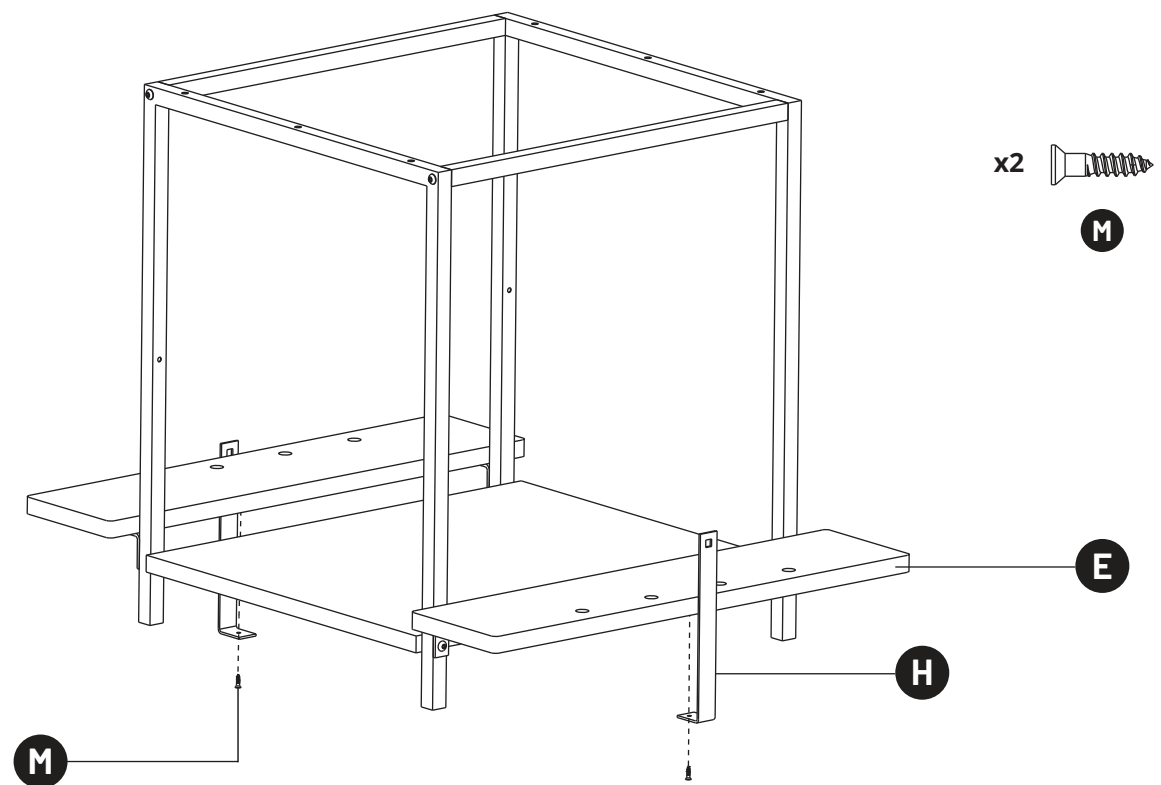

5

Install the Padded Ski Divider (I) using the hardware specified below. Ensure the rubberized foam is facing up.

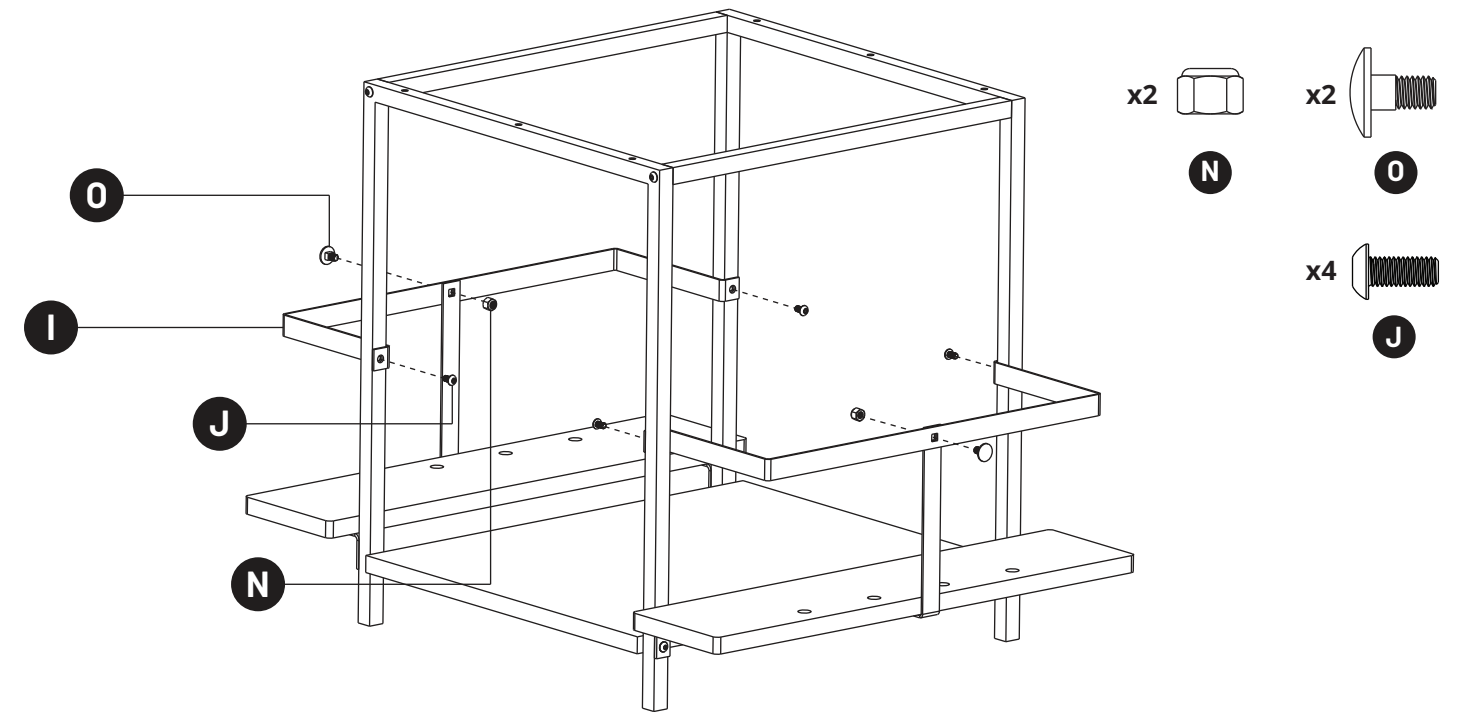

6

Attach the Ski and Pole Shelf (C) and the Middle Shelf (G) to the base using six M5 x 25mm screws (K).

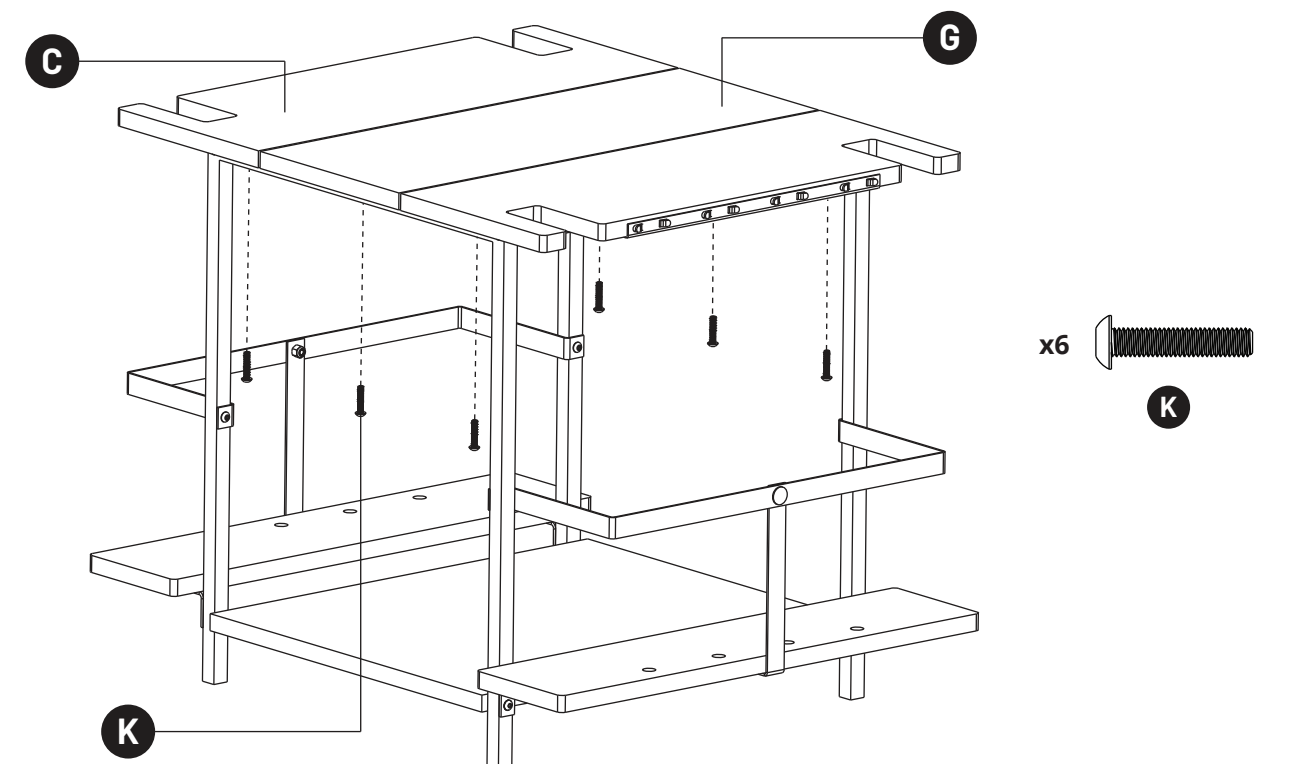

7

Insert a Thumbscrew Spacer (Q) into the looped end of each Leather Strap (S).

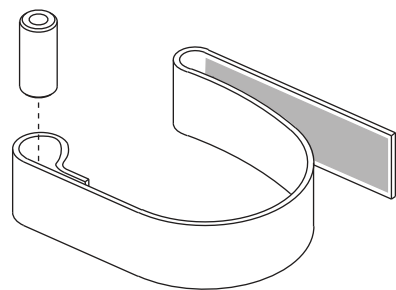

8

Attach the Leather Straps (S) by screwing the Thumbscrew (P) into the underside of the Ski and Pole Shelf (C).

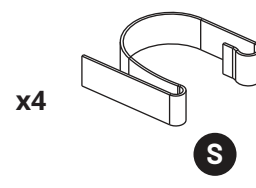
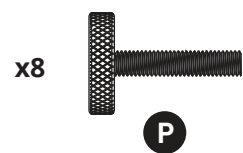
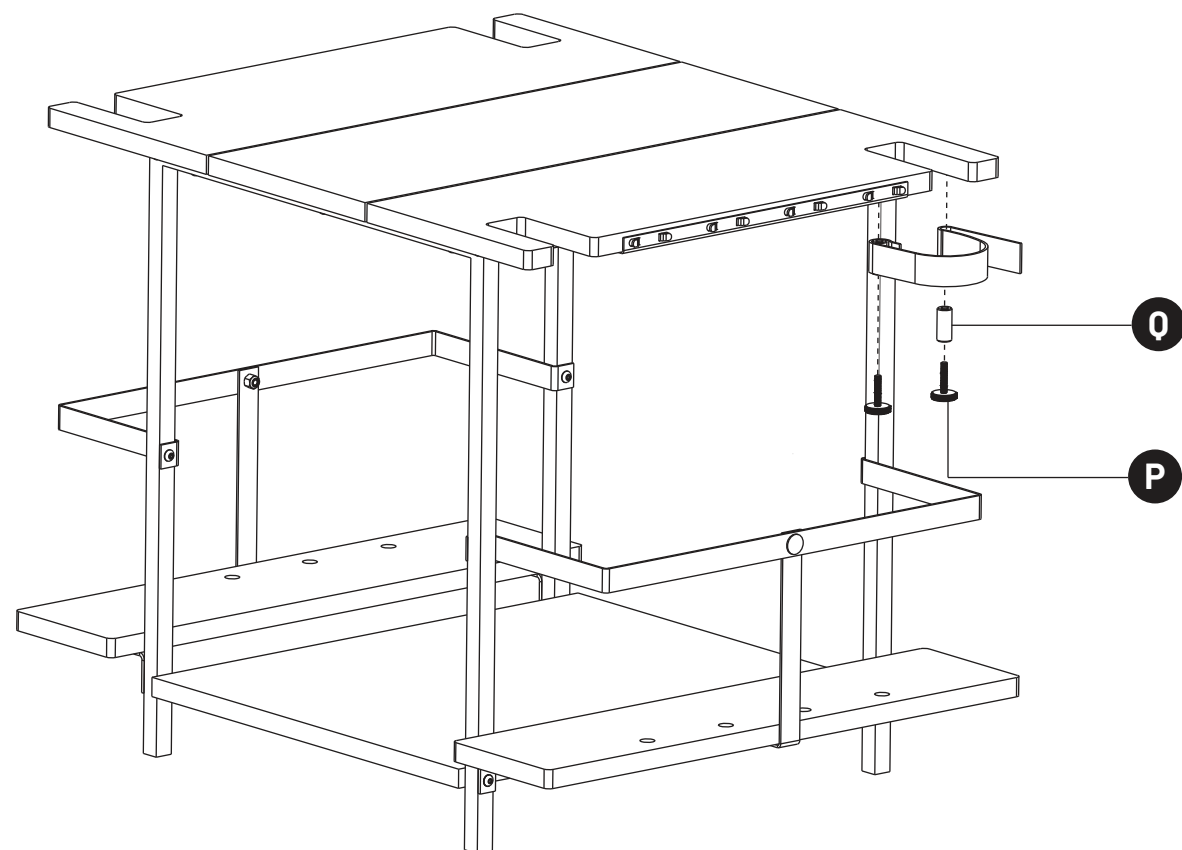

9

Place your skis together with the binding brake intertwined. Loosen the strap and slide the skis carefully over the Padded Ski Divider (I). Wrap the strap around the skis as seen in the image A-A below. Elastic Ski Pole Keepers (R) can be used to secure the ski poles.

A-A (Bottom looking up)

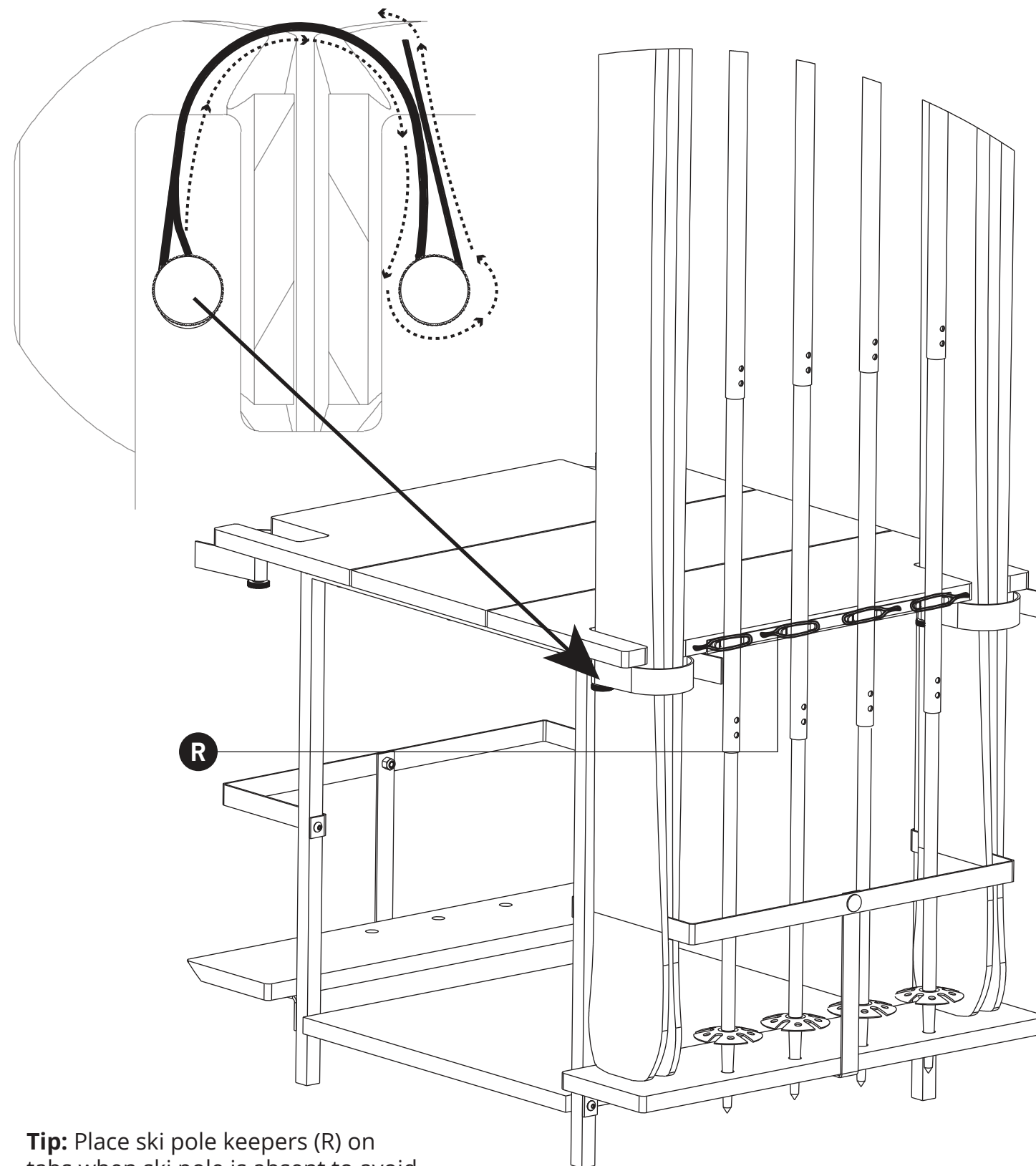

Tip: Place ski pole keepers (R) on tabs when ski pole is absent to avoid loss.