

INSTALLATION GUIDE

TOOL MAX SINGLE

IMPORTANT INFORMATION

Tool Max Single

Manufactured for Spire LLC by Tellbe in Vietnam

Quantity: 1

WARNING! The Tool Max Single is NOT intended for use by any person under the age of 18 years old. You must be over the age of 18 to install or use the Tool Max Single.

WARNING! Strictly follow all instructions to avoid an accident, damage to property, personal injury or death.

WARNING! Do not use this product for human suspension. Components can fail causing person to fall, possibly resulting in serious injury or death.

WARNING! When operating system, make sure the area below object is clear of persons. If object comes down too quickly, this can cause an accident.

READ THE ENTIRE USER MANUAL BEFORE INSTALLATION

The User Manual you received with your Tool Max Single provides instructions on how to install and use your Tool Max Single. The instructions are written for a person with a basic understanding of tools and procedures. Read the entire manual before proceeding. If you do not understand any portion of the instructions, do not attempt installation, and email info@storeyourboard.com.

CORRECTLY INSTALL THE PRODUCT

Read and follow all instructions carefully.

Failure to properly install and use the Tool Max Single could allow the product to detach from the wall, injuring persons or personal property in the process. Accordingly, it is critical that the Tool Max Single be installed correctly and according to the instructions in the User Manual.

USE TOOLS SAFELY

The procedures in the User Manual may require climbing ladders and/or operating power tools. Make sure you are familiar with these tools and their safety procedures before attempting to use such tools during installation. Always be aware of electrical wires during installation. Failure to do so could result in an electrical shock or death.

WARNING!

Contact with wires can give you a severe electrical shock, which may cause injury or death. If you do not know where wires are, have the work done by an experienced professional.

IMPORTANT INFORMATION

CAUTION

It is the consumer's responsibility to install this system in accordance with all codes, ordinances, and local regulations.

When installing Tool Max Single, it is the consumer's responsibility to ensure the structural integrity of the structure it is being mounted to.

The Tool Max Single is intended for the storage of tools only. Do not use it for any other purpose.

This system has a maximum capacity of 50 lbs. per unit. Overloading the system could result in damage to property or injury.

Use extreme caution when loading and unloading equipment from this system.

It is the consumer's responsibility to ensure that the system is in proper working condition before loading objects onto the system. Check tightness of all bolts and screws periodically. Failure to properly maintain the system could result in damage to property or injury.

WARNING AND DISCLAIMER

Spire LLC (d/b/a StoreYourBoard) expressly disclaims any and all liability for personal injury, property damage or loss, whether direct, indirect, incidental, resulting from the incorrect mounting, improper use, inadequate maintenance, or neglect of this system.

INSTALLATION

NOTE: Tool Max Single must be mounted to a wall stud to achieve the advertised weight limit

Wall Rack
Qty: 1

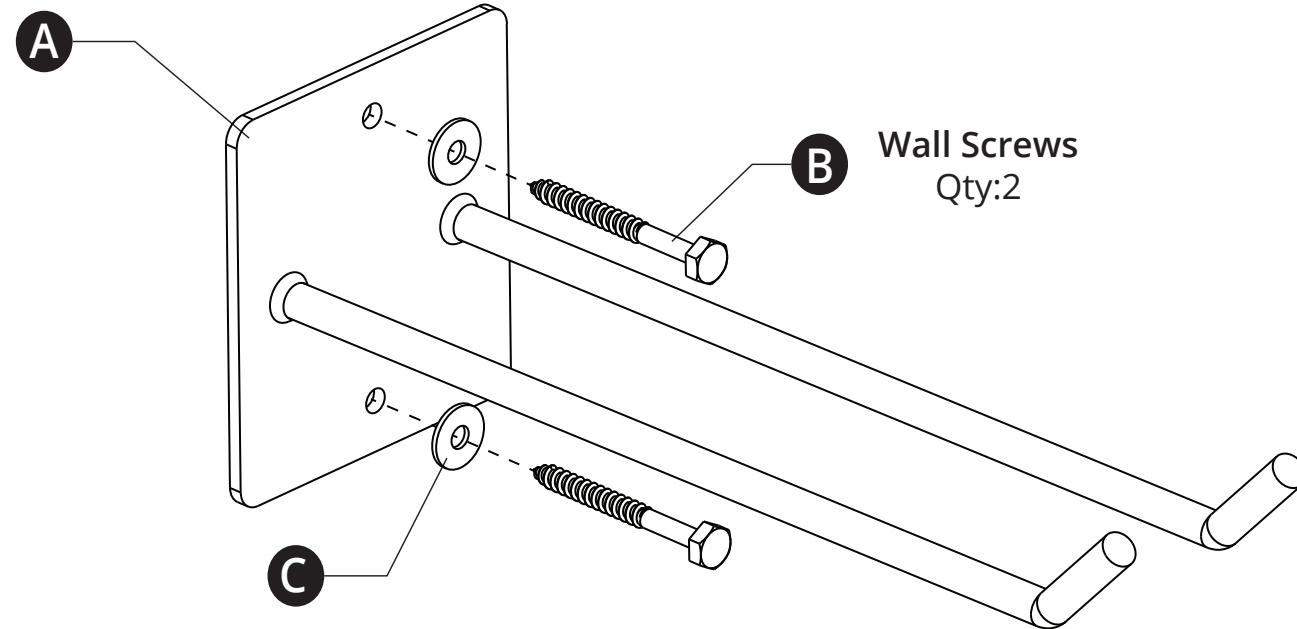

Wall Screws
Qty:2

Machine Washers
Qty:2

1

Use a stud finder to find a wall stud where you want to mount the product and mark the location with a pencil.

2

Hold the rack up to the wall where you want to mount it and align the mounting hole with the stud location. Use a level to ensure the rack sits flat to the ground and mark the mounting holes along the stud.

3

Use a 3/16 inch (4.7mm) drill bit to drill pilot holes into the stud where you marked them.

4

A Machine Washer (C) should be used between the Wall Rack (A) and the Wall Screw (B) as shown in the figure below. Insert the Wall Screws (B) with Machine Washers (C) into the pilot holes to mount the rack.

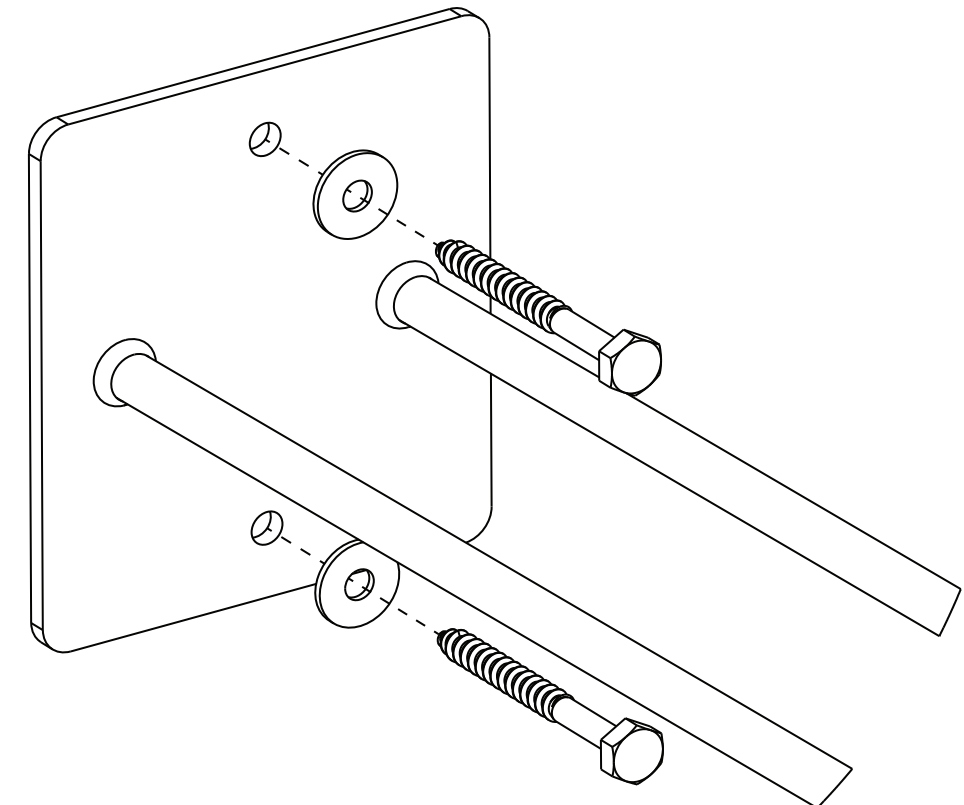

RECOMMENDED TOOLS:

Drill/Driver
Drill bits
Socket/Driver
Level
Tape measure
Pencil
Stud finder

WEIGHT LIMITS:

50 lbs. max per unit